



Instructor Guide

INTRODUCTION TO DRILLING OPERATIONS



Module 5.2
Define the Function of BOP System Parts

D&WO HR Training & Competency Development Division
Published by T&D
August 2014



Trainee Handbook

INTRODUCTION TO DRILLING OPERATIONS



Module 5.2
Define the Function of BOP System Parts

D&WO HR Training & Competency Development Division
Published by T&D
August 2014

Unit 5: State the Function and Operation of Wellhead and Well Control Equipment

**Module 5.2
Define the Function of BOP System Parts**

INSTRUCTOR GUIDE

Teaching Plan	i
Teaching Plan Addendum	ii
Change Record	iv
Information Sheets	1
Exercise A	8
Exercise B.....	16
Glossary.....	17
Test Answer Key	19

Unit 5: State the Function and Operation of Wellhead and Well Control Equipment

**Module 5.2
Define the Function of BOP System Parts**

TRAINEE HANDBOOK

Information Sheets 1
 Exercise A 8
 Exercise B..... 16
Glossary..... 17

Item	Action	Aid	Time
PREPARATION	Before class, prepare the classroom. Distribute trainee handbooks.	Instructor Guide. Trainee Handbooks.	
INTRODUCTION	Identify and explain the module objectives. Explain new words.	Information Sheets. Glossary. Oil Industry Terms e-Glossary	1 hr.
OBJECTIVE 5.2.1	Identify the function of the main components of an annular BOP. Have trainees complete the exercise.	Information Sheets, part I. Exercise A.	3 hr.
OBJECTIVE 5.2.2	Identify the function of the main components of a ram BOP. Have trainees complete the exercise.	Information Sheets, part II. Exercise B.	3 hr.
RIG VISIT	Review the function of the main BOP components and maintenance procedures.	Information Sheets.	4 hr.
REVIEW	Review objectives.	Information Sheets.	1 hr.
WRITTEN TEST	Administer the written test. Score and record the results. Counsel trainees whose performance is unsatisfactory and provide remedial training as required.	Test Sheets. Test Answer Key.	2 hr.
	Estimated time for a class of 8 trainees.		14 hr.

USING THIS MODULE

This module familiarizes trainees with the main components of the BOP stack. Use the Saudi Aramco Oil Industry Terms e-Glossary and other online resources to explain new terms or concepts.

The key objectives to emphasize in this module are:

- components of the annular preventer
- components of ram preventers

RIG VISIT

Use the training rig as much as possible to show your trainees the areas and equipment discussed in the module. Also, use demonstrations in place of lectures wherever possible. Keep the Information Sheets as the core reference material for trainees to review information on the equipment that they have been learning about.

KEY TO EXERCISES

EXERCISE A

1. Head and body.
2. Piston and packing element.
3. Seals.
4. To maintain the shape of the annular while compressed, and to return it to its normal shape when the annular is opened.
5. Grease the tool joint and remove any sharp edges with a file.
6. Allows access for hydraulic oil to enter the opening and closing chambers.

EXERCISE B

1. Bottom side.
2. Attach high pressure valves/Divert fluid during a kick.
3. Accumulator.
4. Warns when a seal is worn or damaged.
5. Long threaded rod that locks or manually closes the rams.
6. Seals.

Date	Reason
August 2014	First Printing

Enabling Objectives

You will, correctly and without help, be able to:

5.2.1

Identify the function of the main components of an annular BOP.

5.2.2

Identify the function of the main components of a ram BOP.

.....

INTRODUCTION

To control the well after a kick has been taken, it is important that the well control equipment operates correctly. The equipment must be maintained and tested regularly to confirm that it is in good working condition.

The well control equipment requires regular visual inspections. Component sizes must be checked and pressure tested as a routine job on the rig. Well control equipment must also be lubricated, transported and stored correctly.

In this module, you will learn about the components and their function for the annular and ram preventers. 

Terminal Objective

Define the function of the BOP system parts.

PART I

OBJECTIVE 5.2.1

Identify the Function of the Main Components of an Annular BOP

As you have learned, the annular preventer houses a large rubber diaphragm called the annular packing element. It seals around the pipe or the kelly inside the BOP. In an emergency with no pipe in the hole, it will also seal the open hole. During normal drilling operations the annular preventer is open. Here you will learn about the main components of an annular preventer.

ANNULAR PREVENTER COMPONENTS

The annular preventer is a steel *vessel* that contains pressurized hydraulic fluid. It uses the pressure to control the opening and closing of the annular packing element. The main components of the annular preventer are:

- head and body
- piston and seals
- packing element

Head and Body

The head and body are the outer parts of the annular preventer, as shown in figure 1. The head is the removable piece on top of the annular. The head can be a screw-on style head, or attached to the body of the annular by studs or tie down bolts. Removing the head allows access to the packing element and seals.

The videos BOP.mov and BLOWOUT.mov show a BOP in position at the rig, and a blowout at a rigsite.

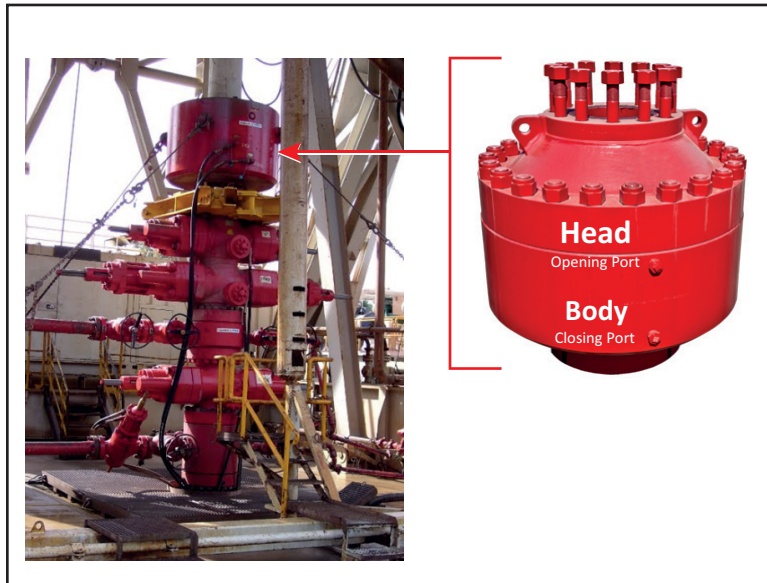

Figure 1
Annular Preventer

The body contains the moving parts of the annular preventer. The body also has ports to direct hydraulic oil into the opening or closing chambers of the piston assembly.

The body is the largest part of the annular preventer. It has a **flanged** connection on the bottom to attach the annular to the ram preventers or other flanged equipment. There are also tie down eyes built into the body for lifting the annular or for securing to the rig substructure while drilling.

Piston and Seals

The animation Annular.mov shows how the pistons operate to seal against the pipe.

The piston is housed within the body of the annular preventer. The piston is sealed against the body of the annular as shown in figure 2. These seals against the annular body separate the opening and closing chambers.

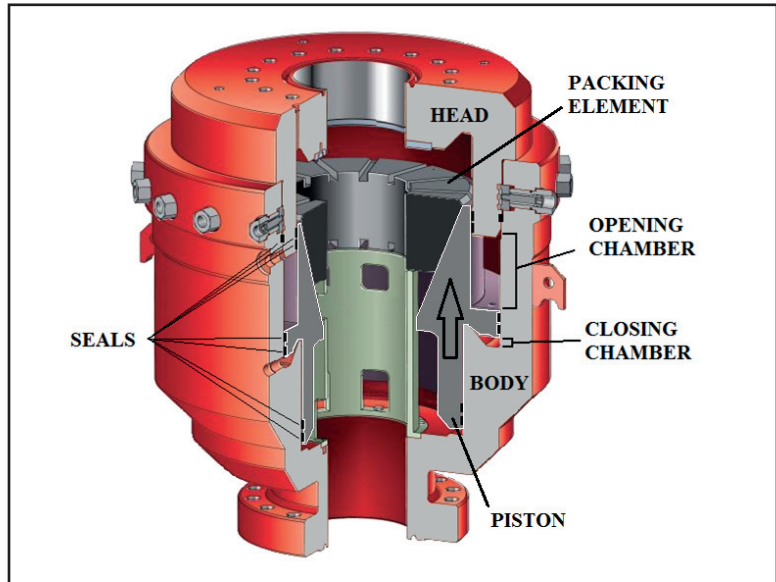

Figure 2
Opening/Closing Chambers in Annular Preventer

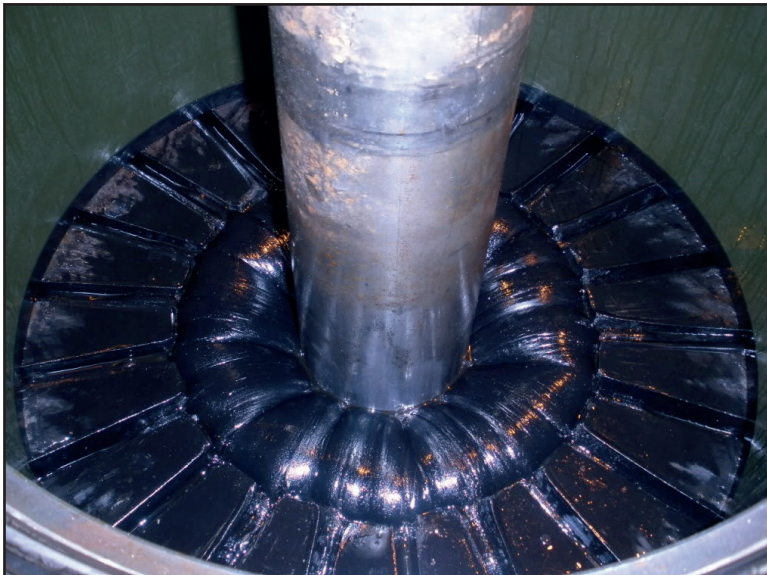

Figure 3
Annular Closed on Drill Pipe

The piston is forced upward when the closing chamber is filled with hydraulic oil. The piston pushes the packing element against the top of the annular head, forcing it inward. As shown in figure 3, this creates the seal around the pipe when it is inside the BOP.

The piston is forced downward when the opening chamber is filled with hydraulic oil. This allows the rubber element to return to its natural shape. The drill string is then free to move through the BOP.

In an emergency, the element can be closed on an open hole without pipe or the kelly inside the BOP (see figure 4). This method of shutting in the well is used only in emergencies. Closing on an open hole can damage the packing element.

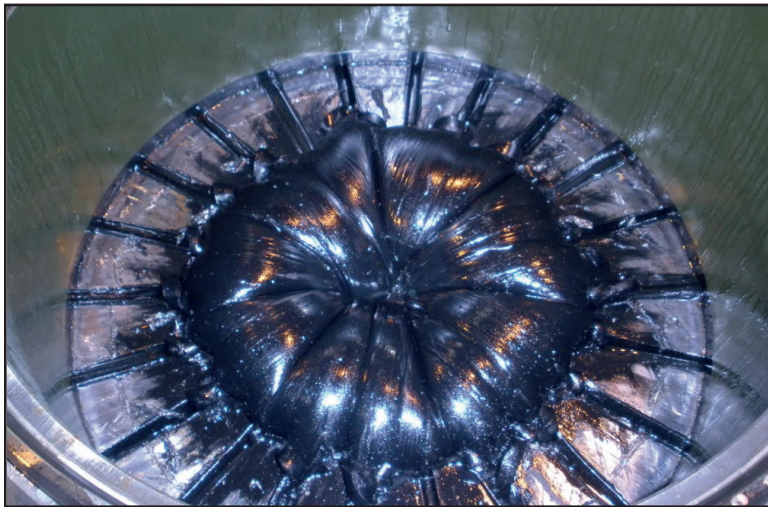

Figure 4
Annular Closed on an Open Hole

Packing Element

The packing element is a large rubber ring (see figure 5) that is strengthened with metal inserts. The inserts also help the rubber to keep its shape when compressed, and to return to its original shape after it has been closed on the pipe.

When closed, the rubber packing element allows the drill pipe tooljoint to pass through while “stripping” in or out of the hole. Stripping is when the drill pipe is pulled or pushed through a closed annular during well control operations.

Sharp points on the drill pipe, such as tong marks or slip marks, can damage the packing element. Sharp metal points on drill pipe must be filed smooth by hand. The outside of tooljoints are greased before they are forced through the closed annular.

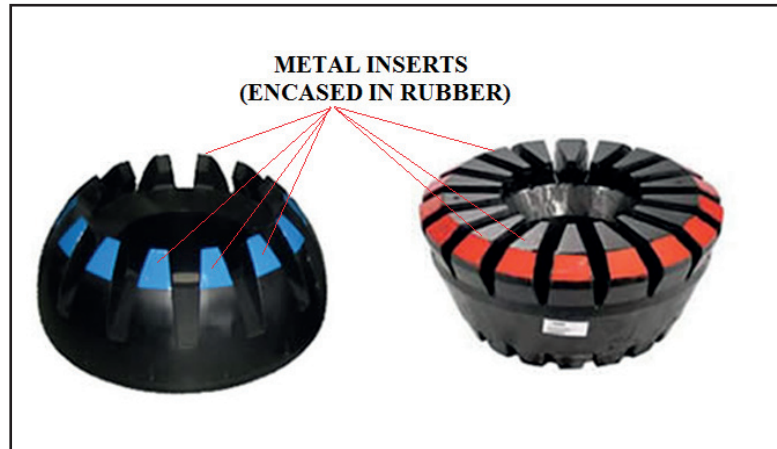

Figure 5
Annular Packing Element

SUMMARY

You have learned about the function of the main components of the annular BOP. You know that the annular preventer houses a rubber ring for sealing against the drilling string in the BOP. You also know that the annular can be closed and seal on an open hole. This is only done in an emergency because the sealing element can get damaged.

The external parts you see on an annular are the head and body. The body has two ports, one to open and one to close the annular.

Inside the annular there is a piston with seals that seal onto the inside of the annular body to make the opening and closing chambers. The piston is forced upward to close the annular, and forced downward to open the annular.

The metal inserts in the packing element help to keep the shape of the packing element when compressed, and help the element return to its normal shape when the annular is opened.

Stripping pipe through the annular means that pipe is either forced into or out of the well with the annular closed. Metal pieces and sharp edges need to be removed when stripping pipe and the tooljoints need to be lubricated. 

EXERCISE A

Directions: Answer the following questions or complete the statement.

1. What are the names of the outer parts of an annular preventer?

2. What are the names of the moving parts of the annular preventer?

3. What separates the opening and closing chambers between the piston and the body of the annular?

4. What is the function of the metal inserts in a packing element?

5. What two things do you need to do to a drill pipe when stripping through an annular?

6. What is the function of the ports on the body of the annular?

PART II**OBJECTIVE 5.2.2****Identify the Function of the Main Components of a Ram BOP**

You have learned that the annular preventer seals around the pipe or the kelly inside the BOP. In an emergency, it can also seal the open hole with no pipe in the hole.

In an emergency, it is important to stop the flow of the well as quickly as possible. One method is to close the well with the ram type preventers because they close the well faster than an annular.

The ram type preventer uses rubber seals mounted onto heavy metal blocks (ram blocks) to seal off the well. In most cases the ram preventers can close with pipe in the well.

In this part, you will learn about the function of the ram type preventers and what each type are designed for. You will also learn how a ram preventer is different from an annular preventer.

RAM PREVENTERS

In a BOP stack, the ram type preventers are located below the annular preventer (see figure 6). The main components of a ram preventer include:

- body
- bonnet
- manual lock
- ram blocks

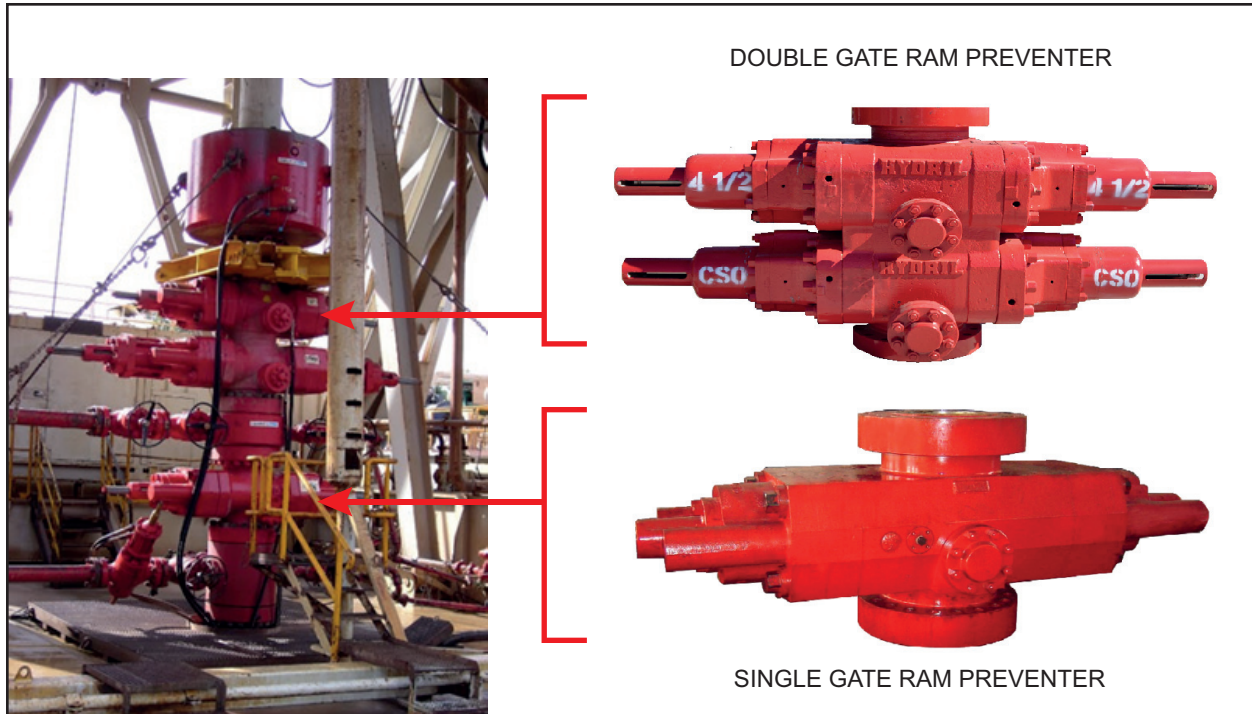

Figure 6
Ram Preventer

BODY

The body of the ram preventer is a large pressure vessel. In a well control situation the body contains the wellbore pressure. The ram blocks seal against the pipe, the ram preventer body, and each other, to prevent the release of pressure from the well.

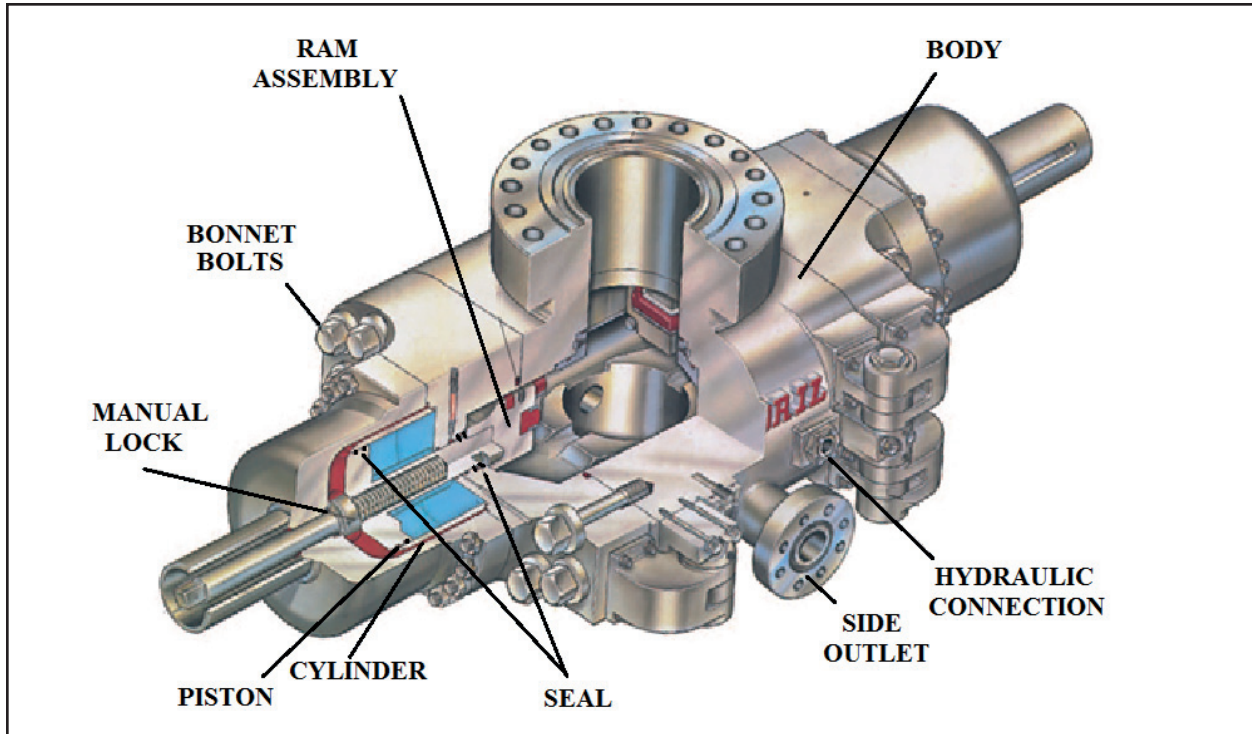

Figure 7
Ram Preventer Parts

The top of the ram preventer body connects to the bottom of the annular preventer body. The bottom of the ram preventer body connects to another ram preventer or to equipment such as a drilling spool (see figure 8).

The body has hydraulic ports for opening and closing the rams. The hydraulic ports connect to the closing/opening chambers inside the bonnet. As with the annular preventer, the ram preventer receives hydraulic power from the accumulator system.

Bonnet

The bonnet of the ram preventers are mounted onto the body of the ram preventer by either a *hinge* or a pin assembly (figure 7). To change the ram blocks, the bonnet is separated from the body.

Drilling spools come in various sizes and configurations. They are usually equipped with side outlets for the addition of high pressure valves. The purpose of these valves is to divert the flow from the well to the choke manifold.



Figure 8
Drilling Spool

The bonnet contains the cylinder and the piston that moves the ram blocks to close off the well. The bonnet also contains a manual lock.

To open the rams, hydraulic oil is directed from the accumulator into the cylinder on the open side of the piston. As shown in figure 9, this forces the piston and rams to move away from well center, opening the flow through the BOP.

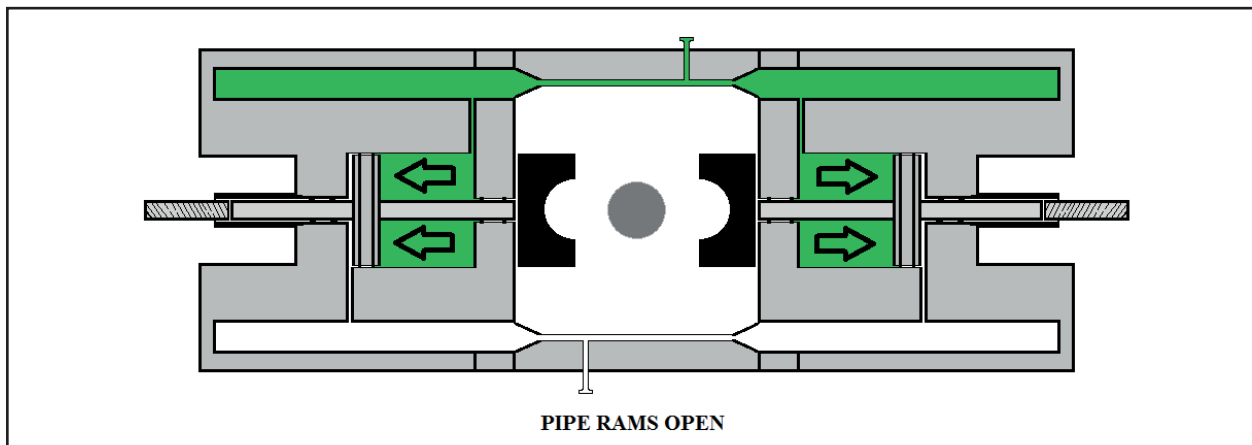

Figure 9
Hydraulic Diagram with Ram Preventer Open

To close the rams, hydraulic oil is pumped from the accumulator into the bonnet cylinder on the closing side of the piston. As shown in figure 10, this forces the piston and rams to move towards well center, sealing off the flow from the well.

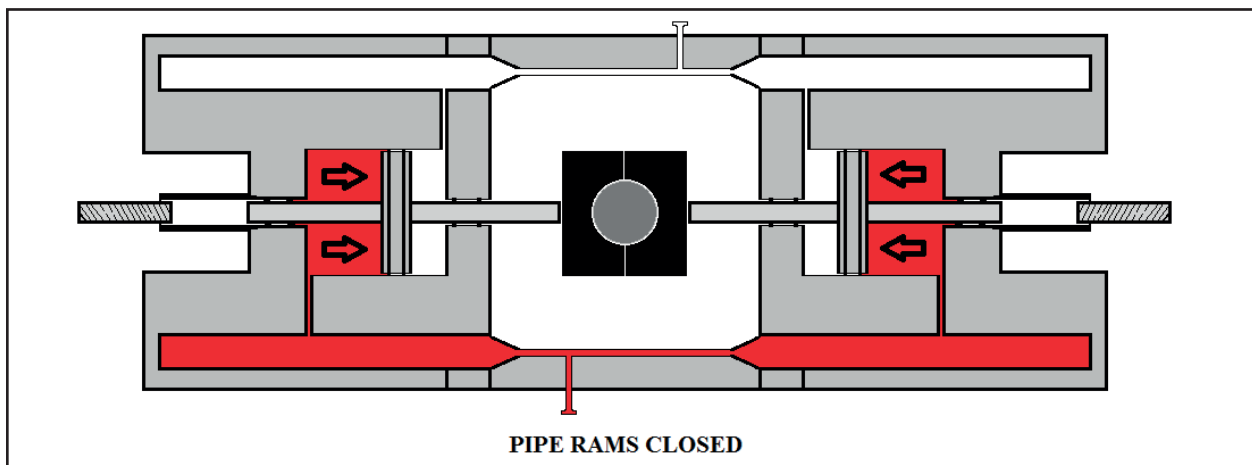

Figure 10
Hydraulic Diagram with Ram Preventer Closed

Shaft seals prevent hydraulic oil from leaking out of the opening chamber into the wellbore. The seals also prevent the wellbore pressure from entering the opening chambers of the bonnet.

The volume of the cylinder in the bonnet is smaller than the chamber in the annular preventer. This is why the ram preventers close faster.

If mud or hydraulic oil leaks out of a “weep hole”, it is a warning that one of the seals is not functioning correctly or is worn. A weep hole is simply a small hole. It is located between the inner and outer seals of the bonnet and piston shaft.

Manual Lock

The manual lock (figure 11) is used to close the rams by hand if the hydraulic pressure fails. It is also a backup to ensure the rams stay closed during well control operations or rig evacuation.

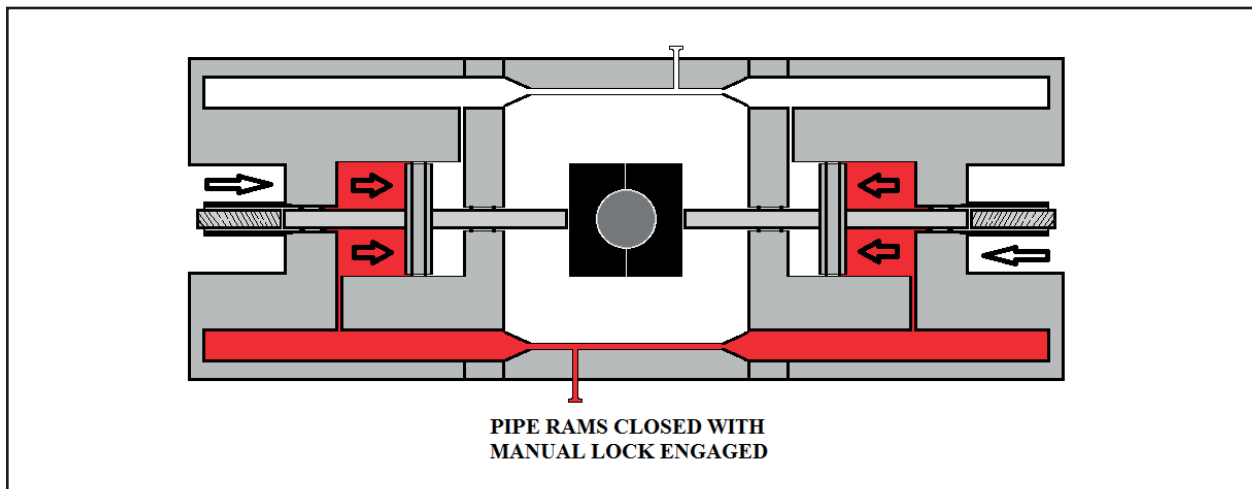

Figure 11
Hydraulic Diagram with Ram Preventer Closed and Manual Lock Engaged

The manual lock is a long threaded rod similar to a bolt. The outer body of the bonnet is threaded to allow the lock to be turned in or out of the bonnet.

Ram Blocks

The ram blocks are the parts that seal off the well. As shown in figure 12, they are steel blocks with rubber inserts.

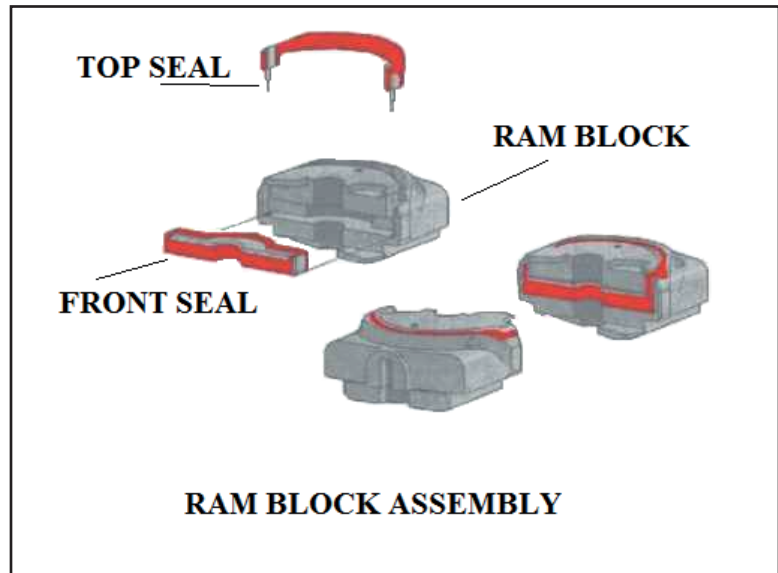

Figure 12
Ram Block Assembly

You learned that the ram blocks come in different styles and sizes. Blind rams or blind shear rams can close off the open hole. Pipe rams can close around pipe or tubular in the well.

Pipe rams are limited to certain sizes of tubular they can close onto. For example, 5" pipe rams can only seal on the stem of tools with an outer diameter of 5". This is why there are usually two or three sets of ram preventers on the BOP. There must be separate ram blocks for both drill pipe and drill collars if they are both in the drill string.

When the rams are closed and seal correctly, the pressure is contained below the ram blocks. There should be no pressure above the rams. The flow from the wellbore is diverted to the choke manifold through the drilling spool.

SUMMARY

In this part of the module, you learned the basic function of the ram type preventer. You learned that the body of the ram preventer contains the pressure from the wellbore.

The ram preventer is below the annular. A drilling spool or other equipment is mounted below the ram preventer. High pressure valves attach to the drilling spool to divert the flow from the well.

The bonnet of the ram preventer contains the operating piston for opening or closing the rams. The bonnet has seals that prevent mud from entering the bonnet and hydraulic oil from exiting the bonnet.

Hydraulic oil gets pumped into the closing side of the piston to force the rams towards the well center and seals off the well.

The pipe rams only seal on the diameter of pipe they are design to close on. 

EXERCISE B

Directions: Answer the following questions or complete the statement.

1. Which side of the ram preventer contains the wellbore pressure?

2. What is the function of the side outlet on a drilling spool?

3. From where does the ram preventer receive power to open/close?

4. What is the purpose of the weep hole on the ram preventer?

5. What is a manual lock on a ram preventer?

6. What prevents mud from entering the bonnet?

Flange

An edge that sticks out from the end of a pipe or fitting, and is used to attach to another pipe.

Hinge

A movable joint of metal or plastic used to fasten two things together and allow one of them to move, such as a door, or the top on a box.

Vessel

A hollow container for holding liquids or gas.



MAXIMUM: 98**OBJECTIVE 5.2.1**

Directions: For questions 1 through 7, select the correct answer. (7 points each)

1. The _____ of the annular preventer is removed to access the packing element.
 - a. ram
 - b. body
 - c. **head**
 - d. seal
2. The annular preventer packing element closes against the _____ to shut in the well.
 - a. head
 - b. **drill string**
 - c. rams
 - d. drilling spool
3. The movement of the _____ forces the annular preventer packing element to close.
 - a. **piston**
 - b. kelly
 - c. drill pipe
 - d. chamber
4. Pulling or pushing the drill string through a closed annular preventer is known as _____.
 - a. casing
 - b. **stripping**
 - c. tripping
 - d. packing
5. The outside of tool joints must be _____ before they are forced through a closed annular preventer.
 - a. stripped
 - b. broken
 - c. sharpened
 - d. **greased**
6. The _____ of the annular preventer contains the moving parts.
 - a. **body**
 - b. head
 - c. ram
 - d. seal

7. Ports in the body of the annular preventer direct _____ into the chambers to operate the piston.
- a. drilling fluid
 - b. hydraulic oil**
 - c. grease
 - d. solvent

OBJECTIVE 5.2.2

Directions: For questions 8 through 14, select the correct answer. (7 points each)

8. In a BOP stack, the ram preventers are located below the _____.
- a. annular preventer**
 - b. drilling spool
 - c. casing
 - d. choke manifold
9. The ram preventer receives hydraulic power from the _____ system.
- a. circulation
 - b. hoisting
 - c. accumulator**
 - d. rotating
10. _____ rams on the BOP are used to close off on open hole.
- a. drilling
 - b. manual
 - c. pipe
 - d. blind**
11. If the hydraulics fail, the rams can be closed with the _____.
- a. mud pumps
 - b. accumulator
 - c. manual lock**
 - d. drilling spool
12. The _____ on ram preventers contains the pistons that make the rams close.
- a. accumulator
 - b. body
 - c. bonnet**
 - d. blocks
13. When the BOP rams close, any fluid from the well is diverted through the _____.
- a. annular
 - b. accumulator
 - c. cylinder
 - d. drilling spool**

14. Drilling fluid coming out of the _____ on a ram preventer indicates that one of the seals is not functioning.

- a. mud pumps
- b. drilling spool
- c. borehole
- d. **weep hole**

Trainee name		Badge No.		Date		Score	
--------------	--	-----------	--	------	--	-------	--

MAXIMUM: 98

OBJECTIVE 5.2.1

Directions: For questions 1 through 7, select the correct answer. (7 points each)

- The _____ of the annular preventer is removed to access the packing element.
 - ram
 - body
 - head
 - seal
- The annular preventer packing element closes against the _____ to shut in the well.
 - head
 - drill string
 - rams
 - drilling spool
- The movement of the _____ forces the annular preventer packing element to close.
 - piston
 - kelly
 - drill pipe
 - chamber
- Pulling or pushing the drill string through a closed annular preventer is known as _____.
 - casing
 - stripping
 - tripping
 - packing
- The outside of tool joints must be _____ before they are forced through a closed annular preventer.
 - stripped
 - broken
 - sharpened
 - greased
- The _____ of the annular preventer contains the moving parts.
 - body
 - head
 - ram
 - seal

7. Ports in the body of the annular preventer direct _____ into the chambers to operate the piston.
- drilling fluid
 - hydraulic oil
 - grease
 - solvent

OBJECTIVE 5.2.2

Directions: For questions 8 through 14, select the correct answer. (7 points each)

8. In a BOP stack, the ram preventers are located below the _____.
- annular preventer
 - drilling spool
 - casing
 - choke manifold
9. The ram preventer receives hydraulic power from the _____ system.
- circulation
 - hoisting
 - accumulator
 - rotating
10. _____ rams on the BOP are used to close off on open hole.
- drilling
 - manual
 - pipe
 - blind
11. If the hydraulics fail, the rams can be closed with the _____.
- mud pumps
 - accumulator
 - manual lock
 - drilling spool
12. The _____ on ram preventers contains the pistons that make the rams close.
- accumulator
 - body
 - bonnet
 - blocks
13. When the BOP rams close, any fluid from the well is diverted through the _____.
- annular
 - accumulator
 - cylinder
 - drilling spool

14. Drilling fluid coming out of the _____ on a ram preventer indicates that one of the seals is not functioning.

- a. mud pumps
- b. drilling spool
- c. borehole
- d. weep hole